

PART NO.	"A"	"B"	MOUNTING HOLE "L"
BPE-SC-1-01	21.5 [.85]	12.8 [.50]	13 [.51]
BPE-SC-2-01	16 [.63]	12.8 [.50]	13 [.51]
BPE-SC-3-01	34.7 [1.37]	25.8 [1.02]	26 [1.02]

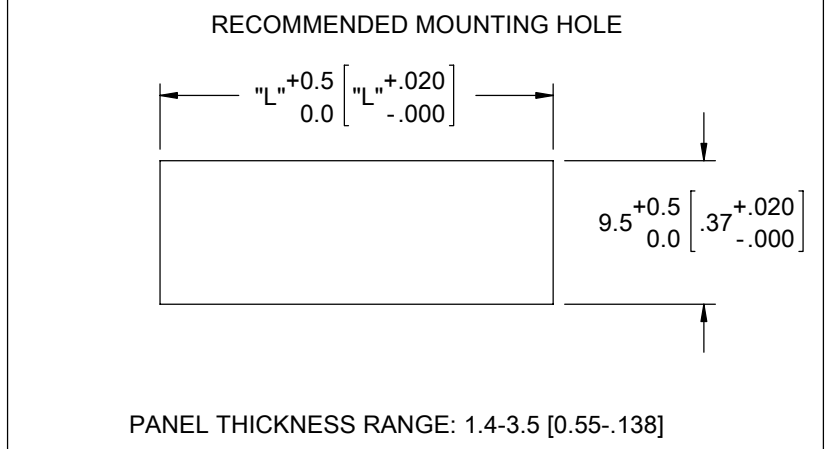
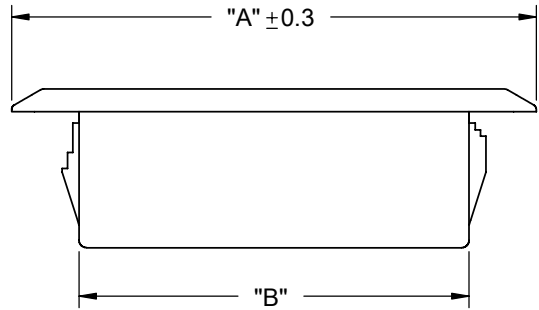
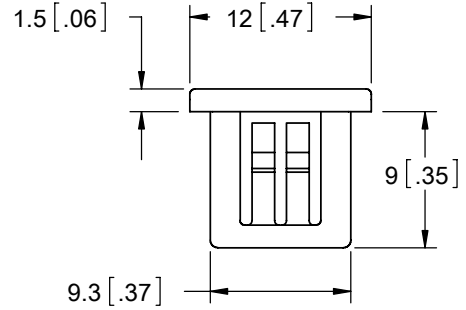

- NOTES:
1. MATERIAL: NYLON 6/6 UL 94 V-2 (RMS-01)
 2. COLOR: BLACK.
 3. ALTERNATE UNITS FOR REFERENCE ONLY

C			REDRAWN, SEE ECN #1292 FOR CHANGES	SK	02/21/07	TITLE: BLANKING PLUG, SQUARE O.F. CONNECTOR						DWG IN mm [IN]	
-			SEE ENGINEERING FOR REVISIONS A-B	-	----	CREATED USING SOLIDWORKS	FILE #: BPE-SC	DWN: SK	APP: SK	FINAL			
REV.			DESCRIPTION	ENGR.	DATE	GENERAL TOLERANCE UNLESS OTHERWISE NOTED	SHEET: 1 OF 1	SHEET SIZE: A	DT: 02/21/07	CHKD: D.Z.	PART #	PRINT TYPE	
						±0.25 ANG. ±1°	RE: RICHCO, INC.	RICHCO, INC. ENG@RICHCO-INC.COM (773) 539-4060		SEE TABLE	CA		